

Composite dry sliding bushings, Composite dry sliding flanged bushings

Principal dimensions					Basic load ratings				Mass	Designation
d	D	D <sub>1</sub>	B	B <sub>1</sub>	radial dynamic C	static C <sub>0</sub>	axial dynamic C <sub>a</sub>	static C <sub>0</sub>		
mm					kN				kg	-
<b>10</b>	12	18	12	1	8	25	8	25	0,0043	PCMF 101212 E

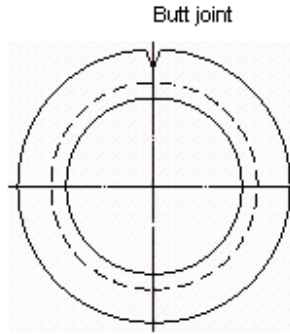
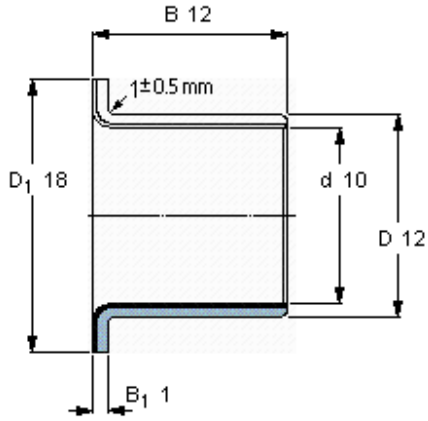

**Specific load factor**  
**Material constant**

K 80  
K<sub>M</sub> 480